

AM-674/75, AM-714

SmartX Actuator Weather Shield Base Mounting Plate

Applications

The AM-674 and the AM-714 weather shields provide moderate weather protection for damper actuators which are mounted outdoors. While these weather shields provide effective, moderate, weather protection, they are not designed as a water-tight enclosure.

The AM-675 base mounting plate is used with the AM-674 and AM-714 weather shields if a suitable mounting surface for the weather shield is not present.

Features

- Provides weather protection for Schneider Electric SmartX actuators. See Model Chart.

Applicable Literature

- MX4X-7XXX and MX40-6XXX Series SmartX Actuator Selection Guide, F-26646
- Cross-Reference Guide, F-23638
- MA4X-7XX3, MA4X-7XX3-50X, MA4X-7XXX, MA4X-7XXX-50X Spring Return Two-Position SmartX Actuators General Instructions, F-26642
- MF4X-7XX3, MF4X-7XX3-50X Spring Return Floating SmartX Actuator General Instructions, F-26644
- MS4X-7XX3, MS4X-7XX3-50X Spring Return Proportional SmartX Actuator General Instructions, F-26645
- MA40-717X Spring Return Direct Coupled SmartX Actuator General Instructions, F-26742
- MF40-6083, MF40-6153 Non-Spring Return Direct Coupled SmartX Actuator General Instructions, F-26743
- MF40-6343 Non-Spring Return Direct Coupled SmartX Actuator General Instructions, F-26744
- MS40-634X SmartX Series Non-Spring Return Direct Coupled Actuator General Instructions, F-26745
- MS40-6083, MF40-6153 SmartX Series Non-Spring Return Direct Coupled Actuator General Instructions, F-26747
- MS40-717X SmartX Series Spring Return Direct Coupled Actuator General Instructions, F-26748
- MF40-7173 SmartX Series Spring Return Direct Coupled Actuator General Instructions, F-26749

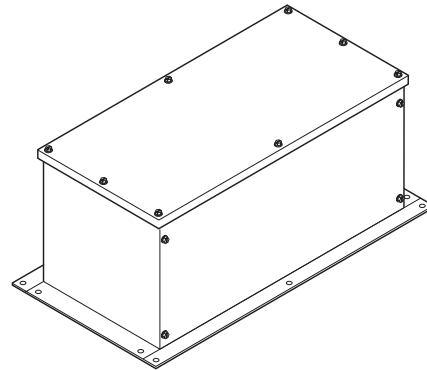

AM-674

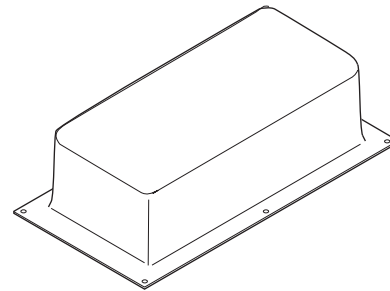

AM-714

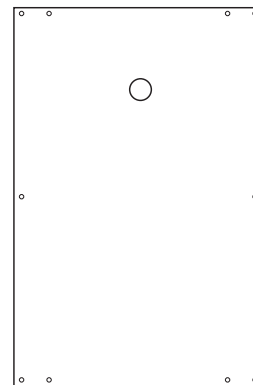

AM-675

Life Is On

Schneider
Electric

Table-1 Model Chart

Model	Description	For Use With
AM-674	Weather Shield	MA40-704X, MF40-7043, MS40-7043, MA4X-707X, MF4X-7073, MS4X-7073, MA4X-715X, MF4X-7153, MS4X-7153, MA40-717X, MF40-7173, MS40-7173, MF40-6083, MS40-6083, MF40-6153, MS40-6153, MF40-6343, MS40-634X
AM-675	Base Mounting Plate	AM-674, AM-714
AM-714	Weather Shield	MA40-704X, MF40-7043, MS40-7043, MA4X-707X, MF4X-7073, MS4X-7073, MA4X-715X, MF4X-7153, MS4X-7153, MF40-6083, MS40-6083, MF40-6153, MS40-6153

Specifications

Material:

- AM-674, 16 GA Galvanized Steel
- AM-675, 12 GA Galvanized Steel
- AM-714, Smoke-tinted Polycarbonate

Installation

Inspection

Inspect the package for damage. If damaged, notify the appropriate carrier immediately. If undamaged, open the package and inspect the device for obvious damage. Return damaged products.

Requirements

Tools (not provided):

- Appropriate screwdriver for the mounting screws used on the weather shield and the base mounting plate
- Training: Installer must be a qualified, experienced technician.
- #8 sheet metal screws (not provided)
- No. 24 drill bit for #8 sheet metal screws
- Other accessories as appropriate
- Wiring diagrams for the applicable hardware

Mounting

Mount the weather shield and base mounting plate onto the damper actuator as follows:

1. The weather shield must be mounted onto a flat, rigid surface that is at least as large as the base of the weather shield. If the actuator mounting surface does not meet this requirement, mount the optional AM-675 base mounting plate before mounting the damper actuator and weather shield, as follows:
 - a. Evaluate the mounting surface to define the number and locations of mounting holes for the base mounting plate.
 - b. Mark the mounting hole locations on the base mounting plate (See Figure-3). Drill the mounting holes at the marked locations.
 - c. Position the base mounting plate on the mounting surface. Transfer the mounting hole locations from the base mounting plate to the mounting surface.
 - d. Drill the holes at the transferred locations in the mounting surface. Secure the base mounting plate to the mounting surface, using the supplied screws.

3. Shorten both ends of the damper actuator's anti-rotation mounting bracket, if necessary to fit inside weather shield, by cutting it at each end (See Figure-1). Mount the damper actuator onto the base mounting plate. Install any accessories onto the actuator, as applicable.

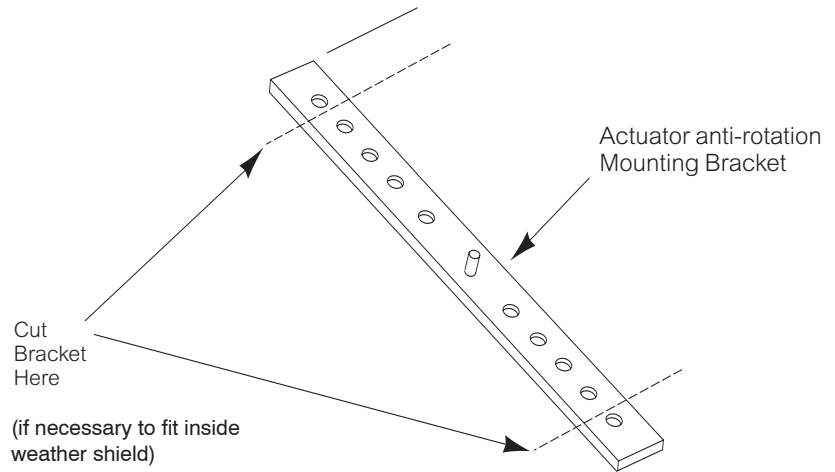

Figure-1 Shortening the Actuator Mounting Bracket.

4. Assemble the weather shield as follows:

Note:

The AM-674 weather shield is supplied disassembled. This allows the following options: to assemble the shield completely so as to totally conceal the damper actuator, or to assemble it partially, leaving the bottom open to provide easy access to the actuator.

- a. Assemble the ends and sides, omitting a side or end as desired, to allow easy access to the actuator.
- b. If the base mounting plate is not used, position the weather shield on the mounting surface. Transfer the mounting hole locations from the weather shield to the mounting surface (See Figure-3). Drill the holes at the transferred locations in the mounting surface.



Caution:

When applying the foam gasket, take care that the gasket is not stretched and that the surface is clean and dry. Stretching the gasket may cause it to shrink and loosen with age.

- c. A foam gasket is supplied with the weather shield. It may be installed to provide a better seal between the weather shield and its mounting surface, or between the cover and the sides of the weather shield. If the foam gasket is to be used on the cover, peel the backing from the gasket, then apply the gasket onto the inside mounting surface of the cover. If the foam gasket is to be used between the weather shield and its mounting surface, peel the backing from the gasket, then apply the gasket onto the mounting flange of the weather shield.
- d. If a more weather-tight installation is desired, apply a silicon sealer on all the inside seams of the weather shield.
- e. Install the weather shield onto the mounting surface or the base mounting plate, if used.

Maintenance

The weather shield and base mounting plate require no maintenance.

Regular maintenance of the total system is recommended to assure sustained, optimum performance.

Visually inspect the AM-714 for moisture build-up inside the shield.

Field Repair

None. Replace any damaged or failed components with functional replacements.

Dimensional Data

See Figure-2 for dimensional data for Weather Shield AM-674.

See Figure-3 for dimensional data for Base Mounting Plate AM-675.

See Figure-4 for dimensional data for Weather Shield AM-714.

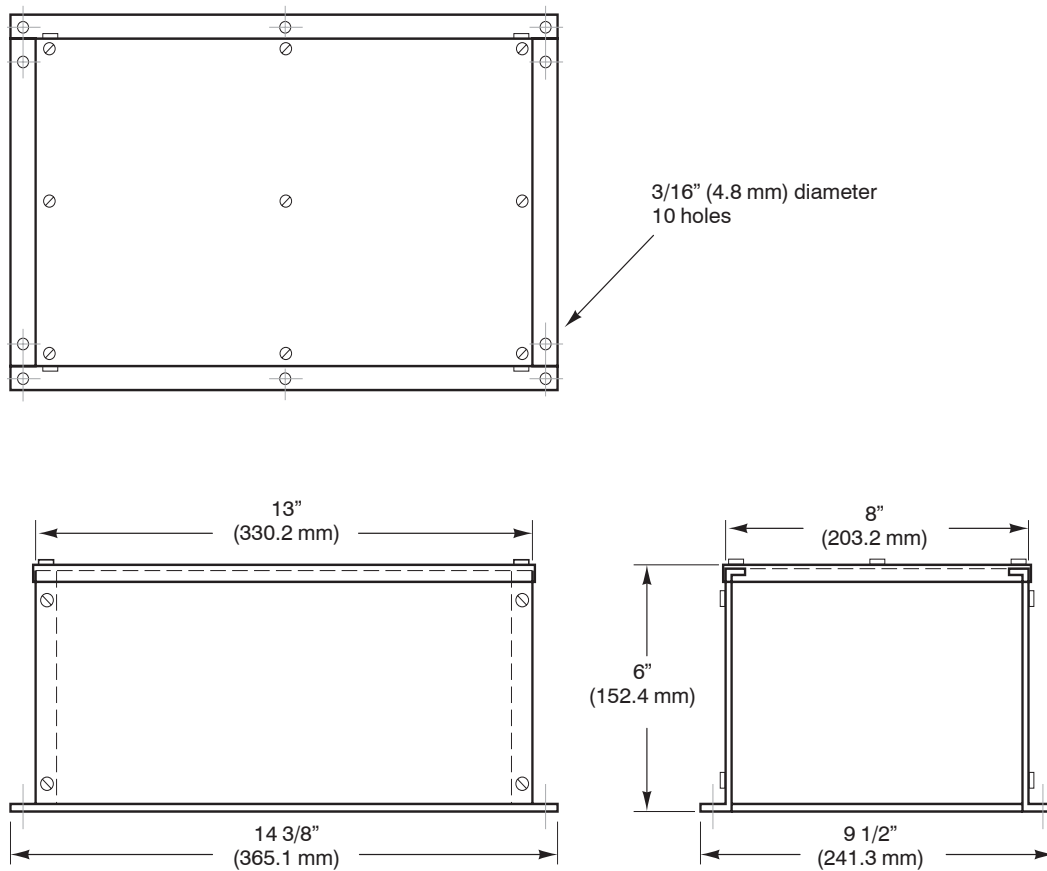

Figure-2 Dimensions of Weather Shield AM-674.

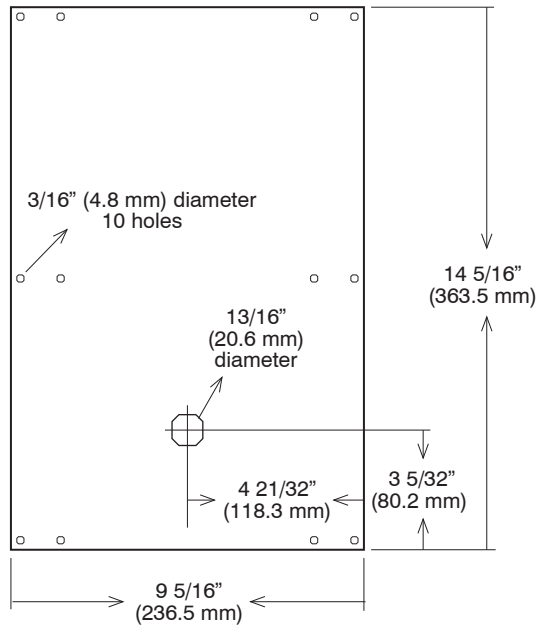

Figure-3 Dimensions of Base Mounting Plate AM-675.

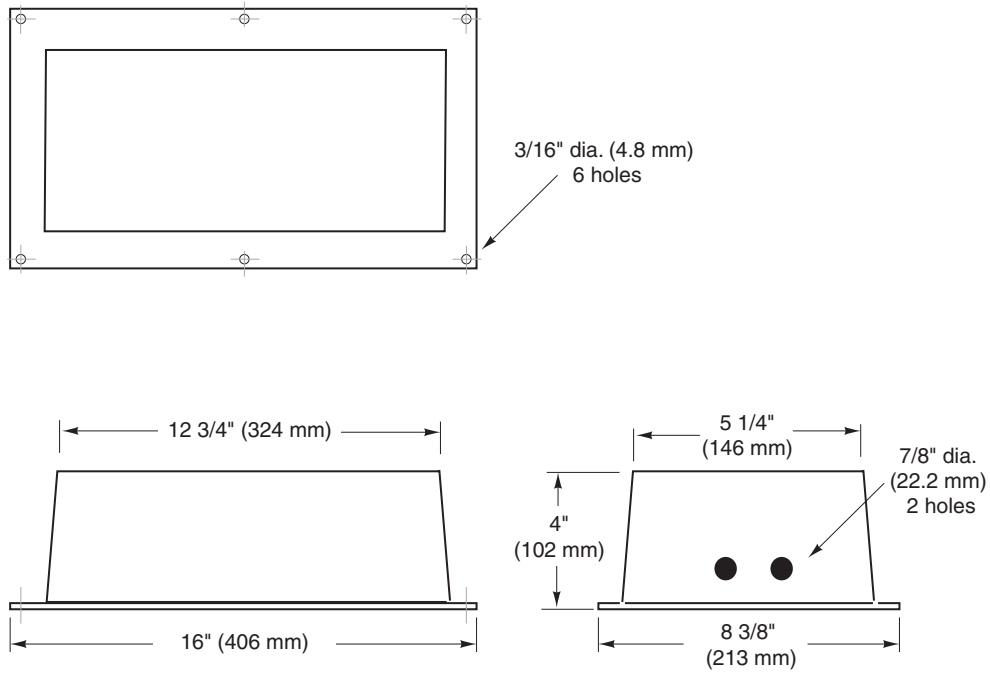

Figure-4 Dimensions of Weather Shield AM-714.

